

# BALANCED ZERO REGULATORS Installation

MODEL: 5101 - BZR

Revision: 0

BULLETIN  
5101

## INSTALLATION

All regulators are factory set and zeroed before shipping. If adjustment or repair is necessary, the regulator should be returned to the factory.

Regulators must always be mounted in a stem-up position, in a horizontal line, as close as practical to the mixer or burner. Any other mounting position will cause a malfunction. The arrow cast on the side of the valve body indicates direction of flow.

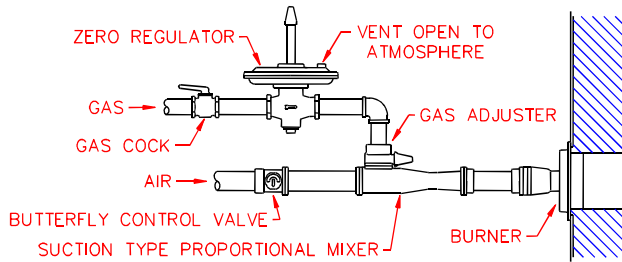

FIG. 1

Standard regulators should not be installed in areas where operating temperatures will exceed 150°F. For high temperature regulators, see the appropriate Bulletin. Where this requirement results in excessive piping, Remote Compensators should be used. (See Bulletin 5109)

One Zero or Balanced Gas Regulator may be manifolded to several mixers under the following conditions: (1) A full area gas cock should be installed at the gas inlet of each mixer so that it may be operated independently. (2) Zero gas piping must be sized so that pressure losses are less than 0.1" w.c. at maximum flow rates. (3) The regulator must be operated within its maximum capacity rating. (4) All mixers supplied by one regulator should be on the same control zone or firing at similar flow rates.

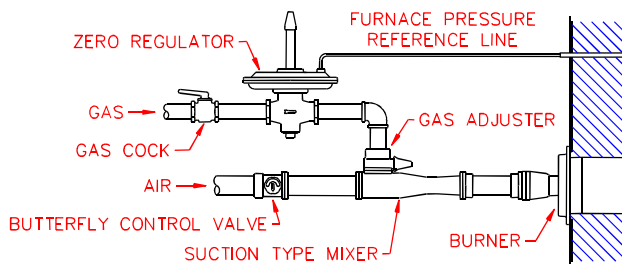

FIG. 2

SUCTION TYPE PROPORTIONAL MIXERS should be connected as shown in Figure 1 when the burner is operated at atmospheric combustion chamber pressure. When the regulator is to be used with a system under positive or negative combustion chamber pressures over 0.03" w. c. a pressure reference connection should be made. This connection of 1/8" pipe or 3/8" tubing (See Figure 2) automatically compensates the system for the furnace pressures.

## TOP DIAPHRAGM LOADING (For Nozzle Mix or Low Suction Systems)

NOZZLE MIXING BURNERS do not produce a proportional suction to operate Zero Regulators and an external pressure must be applied to the top diaphragm chamber of the regulators to open them. With this external pressure proportional to the air pressure, the air to gas ratio will be constant at all flow rates.

Inlet gas pressure to the BZR should be 10" to 14" w.c. higher than the loading air pressure for best ratio control.

A connection from the controlled air chamber of the Nozzle Mixer to the top diaphragm case of the Balanced Regulator provides accurate gas pressures under all firing conditions. (See Figure 3)

When the available gas pressure is less than the combustion air pressure, a 2TDL Loader must be used (see Figure 4 and Bulletin 5108). The loading air pressure applied must be at least 1" w.c. less than the inlet gas pressure. Turndown will be limited and dependent on inlet gas pressure.

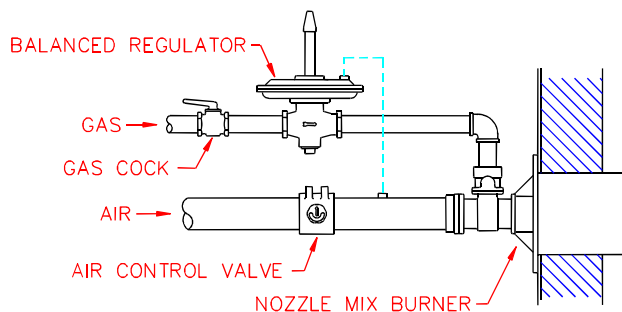

FIG. 3

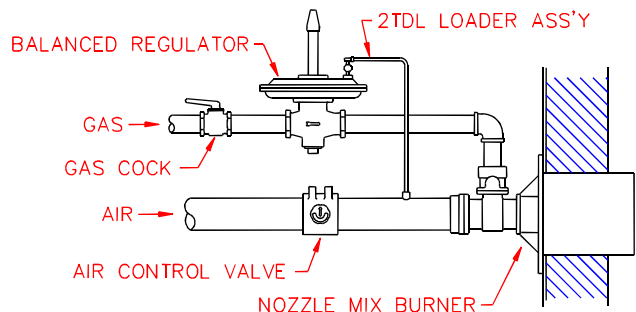

FIG. 4

**CAUTION:** Operation of combustion equipment can be hazardous resulting in bodily injury or equipment damage. Each burner should be supervised by a combustion safeguard and only qualified personnel should install, make system adjustments and perform any required service.



**pyronics inc.**

COMBUSTION FOR INDUSTRY

17700 MILES ROAD  
CLEVELAND, OH 44128  
www.pyronics.com

Tel: 216-662-8800  
Fax: 216-663-8954  
marketing@pyronics.com

**NOTICE:** PYRONICS practices a policy of continuous improvement in the design of its products. It reserves the right to change the specifications at any time without prior notice.