

HMB INSTALLATION

MODEL: 3711

Revision: 0

BULLETIN
3711

During installation refer to the drawings on Page 2.

These instructions pertain only to the HMB series burners.

- 1) The HMB series burner is a self supporting burner and requires no refractories or other mechanical supports to hold the firing tubes. However, the firing tubes must not be used to support the furnace refractory walls and therefore must be sufficient clearance to allow for the walls to expand without placing stresses on the firing tubes. The burner can be mounted in any position including vertically up or down.
- 2) The burner opening must be at least one inch larger than the outside diameter of the firing tubes. The metal shell of the furnace can not touch the firing tubes under any circumstance or mechanical damage will occur.
- 3) Refer to the drawings for the proper mounting stud size and location. The burner should be mounted to the furnace casing by four studs or bolts of the proper size. The burner body can be tightly attached to the furnace casing but should not be used to hold up the air and gas piping, or furnace refractories. Flexible nipples or expansion joints in the air and gas piping are required.
- 4) The firing tubes extend 12" past the burner body mounting flange. The cylindrical portion of the tubes can be exposed to the furnace environment as long as the temperature is 2350°F or less. The conical end of the tubes should not be insulated as this portion of the tube must be allowed to radiated any heat generated by the burner.

For operating temperatures above 2350°F consult factory.

- 5) If the furnace wall is thin and the firing tube will extend far into the furnace cavity, a standoff mounting flange can be used to pull the burner back out of the furnace. The cylindrical portion of the firing tubes does not get hot and therefore only minimal insulation is needed inside the standoff mounting flange. A 1/2" of ceramic fiber is sufficient to insulate the mounting flange cavity.
- 6) If the furnace wall is thicker than 12" and the firing tubes do not extend past the wall, it will still be an acceptable installation as long as the conical end of the tube is not covered with insulation and is allowed to radiate to the furnace cavity.

For specific questions consult the factory.

CAUTION: Operation of combustion equipment can be hazardous resulting in bodily injury or equipment damage. Each burner should be supervised by a combustion safeguard and only qualified personnel should install, make system adjustments and perform any required service.



pyronics inc.
COMBUSTION FOR INDUSTRY

17700 MILES AVE.
CLEVELAND, OHIO 44128
www.pyronics.com

PHONE: (216) 662-8800
FAX: (216) 663-8954
marketing@pyronics.com

NOTICE: Pyronics practices a policy of continuous improvement in the design of its products. It reserves the right to change the specifications at any time without prior notice.

HMB INSTALLATION

350 HMB

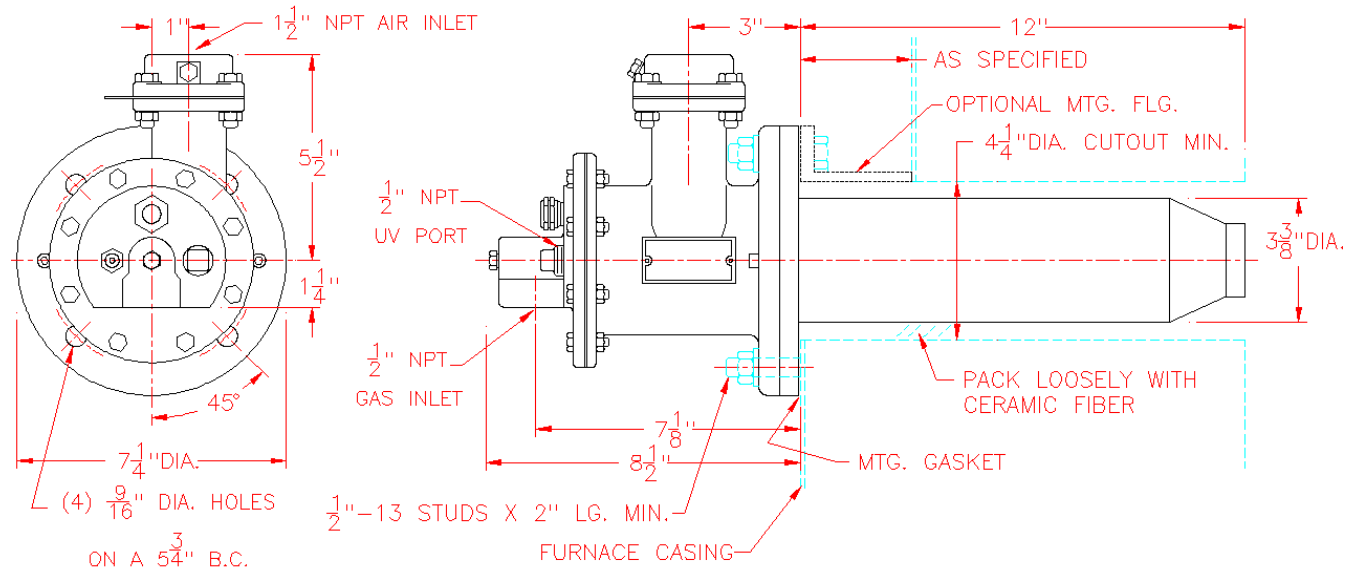

650 HMB

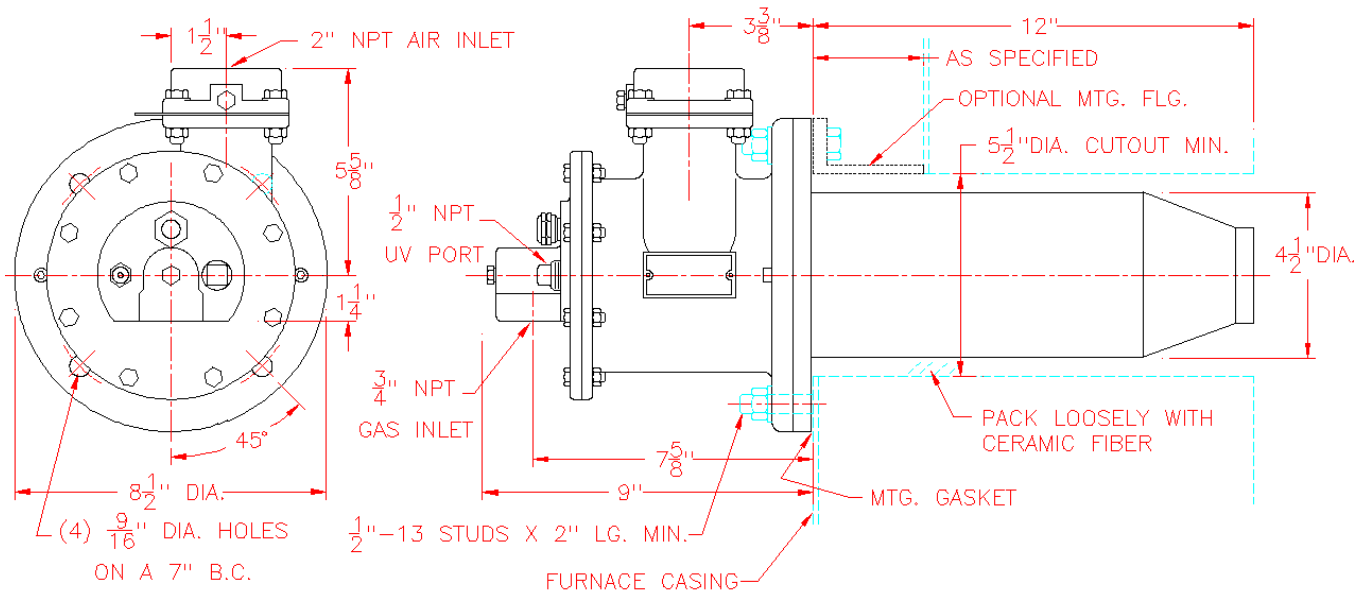

CAUTION: Operation of combustion equipment can be hazardous resulting in bodily injury or equipment damage. Each burner should be supervised by a combustion safeguard and only qualified personnel should install, make system adjustments and perform any required service.