

COIL-CAGE BURNERS

MODEL: A-E SERIES

Revision: 0

BULLETIN
3230

DESCRIPTION

Coil-Cage Burners are complete assemblies for gas firing immersed tubes for heating water, solutions, oils, and other liquids. These assemblies are engineered to allow ample secondary air for good combustion at all times.

Burner selection data and coil size selection tables for any tank to be heated are included on pages 2 to 5. Atmospheric Burner assemblies are listed in capacity table below.

The burner nozzle is centered by set screws and lugs and a pilot bracket may be added even after installation is made.

For pilot assemblies that can be added to any Coil-Cage Burner see Bulletin 3271.

Maximum Burner Input, Coil Length & BTU/SQ. FT. for Various Pipe Coil Sizes*

Pipe Coil Size	Atmospheric Burners		
	Max. Burner Input BTU/hr	Max. Coil Length in Ft.	Max. Input in BTU/ft of Coil Length
2-1/2"	41,500	8.5	4,900
3"	71,000	12	5,900
4"	120,000	16	7,450
5"	165,000	18	9,150
6"	207,000	20	10,350
8"	310,000	25	12,400



* Based on 250°-300°F differential temperature between flue gas & liquid using 4' stack height.

CAPACITY TABLE

Atmospheric Coil-Cage Burner Catalog No.	To Fit Coil Pipe Sizes Shown		Burner Nozzle		Gas Conn. Pipe Size	Burner Capacity in 1000 BTU/hr When Used With Correct Coil Size and Suitable Natural Draft*		
	Max.	Min.	Cat. No.	Pipe Size		Mfd. Gas 450-650 BTU 3" Pressure	Natural Gas 800-1200 BTU 5" Pressure	L. P. Gases 2500-3200 BTU 10"-12" Pressure
20A - E8	2-1/2"	2"	8AN	1"	1/2"	57	38	25
20A - E10			10AN	1-1/4"	3/4"	82	55	40
24A - E10	3"	2-1/2"	10AN	1-1/4"	3/4"	82	55	40
24A - E12			12AN	1-1/2"	3/4"	105	70	52
32A - E12	4"	3"	12AN	1-1/2"	3/4"	105	70	52
32A - E16			16AN	2"	1"	165	110	87
481A - E12	6"	5"	12AN	1-1/2"	3/4"	105	70	52
481A - E16			16AN	2"	1"	165	110	87
482A - E20	6"	5"	20AN	2-1/2"	1"	250	175	125
482A - E24			24AN	3"	1"	375	250	185
641A - E24	8"	8"	24AN	3"	1"	375	250	185
642A - E320			32AN	4"		510-750	340-500	250-375

*With induce draft (0.2" W. C. at burner) ratings can be increased up to 250%.

CAUTION: Operation of combustion equipment can be hazardous resulting in bodily injury or equipment damage. Each burner should be supervised by a combustion safeguard and only qualified personnel should install, make system adjustments and perform any required service.



pyronics inc.
COMBUSTION FOR INDUSTRY

17700 MILES AVE.
CLEVELAND, OHIO 44128
www.pyronics.com

PHONE: (216) 662-8800
FAX: (216) 663-8954
marketing@pyronics.com

NOTICE: Pyronics practices a policy of continuous improvement in the design of its products. It reserves the right to change the specifications at any time without prior notice.

COIL-CAGE BURNERS

GENERAL INFORMATION

The design and selection data contained in the following tables have been employed in applying immersion coil heating equipment to numerous solution and oil heating tanks. If these specifications are followed, satisfactory operation of the heating equipment can be assured.

A reasonably accurate calculation of the net heat required by the immersion heated installation is necessary for the satisfactory application of these tables. This calculation is based on knowing a few basic and readily available facts about the operation. These include the tank, its size, material and whether or not it is insulated, plus the operating temperature and specific heat of the liquid to be heated. These data are used to figure the total evaporation and radiation heat losses, as well as part of the operating heat requirement. Other information, such as the weight of the work per hour, the time allowed to bring the liquid to temperature, the type burner equipment to be used, and the desired flue gas temperature should be available before starting the calculation.

STANDARD PIPE DATA

NOMINAL DIA.	INTERNAL AREA SQ. IN.	SQ. FT. OF OUTER SURFACE PER FT.	DISPLACEMENT DATA	
			GALLONS PER LINER FOOT	COIL LENGTH EQUIVALENT TO I.C.F. LIQUID
2"	3.36	0.622	0.230	32.5
2-1/2"	4.79	0.753	0.337	22.2
3"	7.38	0.916	0.498	15.0
4"	12.73	1.178	0.826	9.1
5"	20.01	1.456	1.26	5.9
6"	28.89	1.734	1.79	4.2
8"	50.03	2.258	3.03	2.6

FIGURE 2

HEAT LOSSES FROM TANKS

LIQUID TEMPERATURE DEGREES F	HEAT LOSS FROM LIQUID SURFACE BTU/SQ. FT./HOUR			HEAT LOSS THRU TANK WALLS BTU/SQ. FT./HOUR			
	EVAPORATION LOSS *	RADIATION LOSS	TOTAL SURFACE HEAT LOSS	BARE STEEL WALLS	1" INSULATION	2" INSULATION	3" INSULATION
90	80	50	130 *	50	12	6	4
100	160	70	230 *	70	15	8	6
110	240	90	330 *	90	19	10	7
120	360	110	470 *	110	23	12	9
130	480	135	615 *	135	27	14	10
140	660	160	820 *	160	31	16	12
150	860	180	1040 *	180	34	18	13
160	1100	210	1310 *	210	38	21	15
170	1380	235	1615 *	235	42	23	16
180	1740	260	2000 *	260	46	25	17
190	2160	290	2450 *	290	50	27	19
200	2680	320	3000 *	320	53	29	20
210	3240	360	3590 *	360	57	31	22
225	-	420	420	420	62	35	23
250	-	510	510	510	70	40	25
275	-	600	600	600	81	45	29
300	-	705	705	705	92	51	33
325	-	850	850	850	103	57	36
350	-	990	990	990	114	63	40
400	-	1335	1335	1335	138	75	49
450	-	1705	1705	1705	162	88	58
500	-	2115	2115	2115	178	101	68
550	-	2570	2570	2570	204	115	78
600	-	3080	3080	3080	232	129	89

HEATING CALCULATIONS

Figure 2 illustrates in detail the steps involved in calculating the various heat losses and requirements, as well as the selection of the proper coil size and burner capacity. It is first necessary to obtain data on the seven items listed in the table. This information can then be used to figure all heat requirements.

The heating up calculations may be divided into four steps, as shown in example :

1. Heat for raising the liquid from its original temperature up to operating temperature in the time selected. In this case the specific heat of water (1.0) is not indicated in the calculation. If other materials are used, this figure may be obtained from standard tables.
2. Radiation and evaporation losses from the exposed surface of the liquid can be easily figured by referring to Figure 1.
3. Radiation losses from tank wall can also be found in Figure 1.
4. Heating the tank material to operating temperature is calculated by using the specific heat of steel (0.2) multiplied by the weight and the temperature rise.

The operating heat requirements may be obtained by using the liquid radiation and evaporation necessary for the hourly work load. In the example, both the total heating up requirements have been figured and the largest picked for use in selecting the coil and burner. It is recommended that this double procedure be followed as under conditions of heavy production the operating requirements may be in excess of the heating up figure. Normally, unless an extended heat up figure can be used.

The next step is to refer the total net heat requirement figure, in this case 119,325 BTU per hour, to the proper table. (see page 5 & 6).

If the coil length selected cannot be arranged to fit the tank, a compromise choice will have to be made. The data can be interpolated to make this selection.

It is possible to obtain higher combustion efficiencies or rather lower flue losses by reducing the gas input per unit of coil length. In general it is not desirable to go to heat transfer rates lower than those shown in the tables because of the excess coil areas and lengths required and the possibilities of trouble from moisture and condensation in stacks.

FIGURE 2
EXAMPLE : SELECTION OF IMMERSION COIL AND BURNER

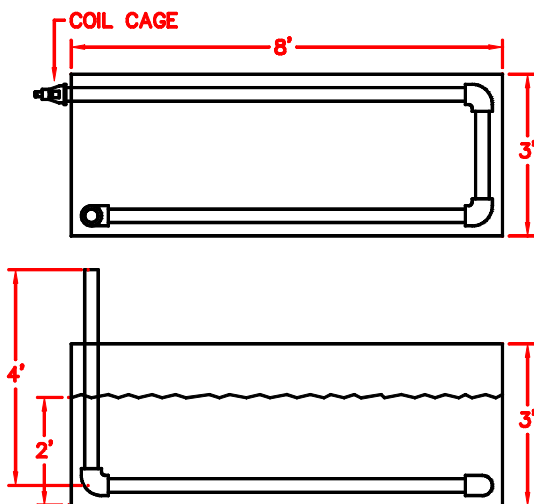

1. Tank - 18" steel, not insulated - 3' x 3' x 8'
2. Liquid - Water base Solution - 24" deep
3. Temperature - 140 degrees F (from 50° F)
4. Load - Steel, 1200 lbs. per hour
5. Allowable heating up time - 3.5 hours
6. Type of Burner - Atmospheric
7. Selected Flue Gas Temperature - 300°-400° F
8. Type of Gas - Natural

CAUTION: Operation of combustion equipment can be hazardous resulting in bodily injury or equipment damage. Each burner should be supervised by a combustion safeguard and only qualified personnel should install, make system adjustments and perform any required service.



pyronics inc.

COMBUSTION FOR INDUSTRY

17700 MILES AVE.
CLEVELAND, OHIO 44128

PHONE: (216) 662-8800
FAX: (216) 663-8954

**PYRONICS
INTERNATIONAL S.A.**
ZONING INDUSTRIEL, 4EME RUE
B-6040 JUMET BELGIUM
PHONE: (32) 71-256970
FAX: (32) 71-256979

COIL-CAGE BURNERS

BULLETIN 3230
PAGE NO. 4

CALCULATION OF HEAT REQUIREMENTS

HEATING UP

- Liquid Heating = 48 cu.ft. x 62.5 = 3000 lbs.

$$\frac{3000 \times (140^{\circ} - 50^{\circ} \text{ F})}{3.5 \text{ hours}} = 77,145 \text{ BTU/hr.}$$
 - Liquid Radiation and Evaporation Loss (From Figure 1)
 24 sq. ft. x 820 BTU/sq. ft. = 19,680 BTU/hr.
 - Tank Radiation Loss (From Figure 1)
 90 sq. ft. x 160 BTU/sq. ft. = 14,400 BTU/hr.
 - Steel Tank - 90 sq. ft. x 5# x 0.2 x 90° = 8,100 BTU/hr.
- TOTAL 119,325 BTU/hr

OPERATING

- Liquid - radiation and Evaporation Loss - 19,680 BTU/hr.
 - Tank Radiation Loss - 14,400 BTU/hr.
 - Load - 1200 lbs. x 0.2 (sp.ht.) x 90 = 21,600 BTU/hr.
- TOTAL 55,680 BTU/hr.

COIL AND BURNER SELECTION

- Hourly net heat requirement = 119,325 BTU
 Use "heating up" or "operating requirement" - which ever is greatest
 From Figure 3 (100 - 200 liquid Temp. - Atmospheric Burner)
- Coil Size - (1) 6" dia. x 17-1/2' long
 Where net heat requirement fall between figures on table, use next larger size.
 - Burner Capacity Required - 145,000 BTU/hr.

FIGURE 3
IMMERSION COIL SELECTION TABLE
LIQUID TEMPERATURE RANGE 100-200 DEGREES F
ATMOSPHERIC BURNERS
STACK HEIGHT 4 FEET

HEAT REQUIREMENT BTU/HR	300-400 DEGREE F FLUE TEMPERATURE			400-600 DEGREE F FLUE TEMPERATURE			600-800 DEGREE F FLUE TEMPERATURE			800-1000 DEGREE F FLUE TEMPERATURE		
	PIPE COIL		GAS INPUT BTU/HR	PIPE COIL		GAS INPUT BTU/HR	PIPE COIL		GAS INPUT BTU/HR	PIPE COIL		GAS INPUT BTU/HR
	DIA.	LGTH.		DIA.	LGTH.		DIA.	LGTH.		DIA.	LGTH.	
20,000	2-1/2"	6'	23,500	2-1/2"	5-1/2'	25,000	2-1/2"	4-1/2'	27,000	2-1/2"	3-1/2'	29,000
40,000	3"	10'	47,000	3"	8-1/2'	50,000	2-1/2"	8-1/2'	54,000	2-1/2"	7'	57,000
60,000	4"	12'	71,000	4"	10'	75,000	3"	10-1/2'	80,000	3"	8-1/2'	86,000
80,000	4"	16'	94,000	4"	13-1/2'	100,000	4"	11'	107,000	3"	11-1/2'	114,000
100,000	6"	14-1/2'	120,000	6"	12'	125,000	4"	13-1/2'	133,000	4"	10'	143,000
125,000	6"	17-1/2'	145,000	6"	15'	155,000	6"	12'	165,000	4"	14'	180,000
150,000	8"	17-1/2'	175,000	6"	18-1/2'	190,000	6"	14-1/2'	200,000	6"	12'	215,000
175,000	8"	20-1/2'	205,000	8"	18'	220,000	6"	17'	235,000	6"	14'	250,000
200,000	8"	23-1/2'	235,000	8"	20-1/2'	250,000	6"	19-1/2'	265,000	6"	16'	285,000
225,000				8"	22-1/2'	280,000	8"	18-1/2'	300,000	6"	18'	320,000
250,000							8"	20-1/2'	335,000	6"	20'	360,000
300,000							8"	24-1/2'	400,000	8"	20'	430,000
350,000										8"	23-1/2'	500,000

NOTE : PIPE COIL LENGTH INCLUDES ELBOWS - 1 ELBOW = 1-1/2 FT OF PIPE

COIL-CAGE BURNERS

BULLETIN 3230
PAGE NO.5

FIGURE 4
IMMERSION COIL SELECTION TABLE
LIQUID TEMPERATURE RANGE 200-400 DEGREES F
ATMOSPHERIC BURNERS
STACK HEIGHT 4 FEET

HEAT REQUIREMENT BTU/HR	400-600 DEGREE F FLUE TEMPERATURE			600-800 DEGREE F FLUE TEMPERATURE			800-1000 DEGREE F FLUE TEMPERATURE		
	PIPE COIL		GAS INPUT BTU/HR	PIPE COIL		GAS INPUT BTU/HR	PIPE COIL		GAS INPUT BTU/HR
	DIA.	LGTH.		DIA.	LGTH.		DIA.	LGTH.	
20,000	2-1/2"	6-1/2'	25,000	2-1/2"	5-1/2'	27,000	2-1/2"	4-1/2'	29,000
40,000	3"	10-1/2'	50,000	3"	9-1/2'	54,000	3"	7-1/2'	57,000
60,000	4"	12-1/2'	75,000	4"	11'	80,000	3"	11'	86,000
80,000	6"	12'	100,000	4"	14-1/2'	107,000	4"	11-1/2'	114,000
100,000	6"	15'	125,000	6"	13'	133,000	6"	10-1/2'	143,000
125,000	6"	19'	155,000	6"	16'	165,000	6"	13'	180,000
150,000	8"	19'	190,000	6"	19-1/2'	200,000	6"	15-1/2'	215,000
175,000	8"	21-1/2'	220,000	8"	19'	235,000	6"	18'	250,000
200,000	8"	25'	250,000	8"	21-1/2'	265,000	8"	17-1/2'	285,000
225,000				8"	24-1/2'	300,000	8"	19-1/2'	320,000
250,000							8"	22'	360,000
275,000							8"	24'	395,000

NOTE : PIPE COIL LENGTH INCLUDES ELBOWS - 1 ELBOW = 1-1/2 FT OF PIPE

FIGURE 4
IMMERSION COIL SELECTION TABLE
LIQUID TEMPERATURE RANGE 400-600 DEGREES F
ATMOSPHERIC BURNERS
STACK HEIGHT 4 FEET

HEAT REQUIREMENT BTU/HR	600-800 DEGREE F FLUE TEMPERATURE			800-1000 DEGREE F FLUE TEMPERATURE			1000-1200 DEGREE F FLUE TEMPERATURE		
	PIPE COIL		GAS INPUT BTU/HR	PIPE COIL		GAS INPUT BTU/HR	PIPE COIL		GAS INPUT BTU/HR
	DIA.	LGTH.		DIA.	LGTH.		DIA.	LGTH.	
20,000	2-1/2"	7'	27,000	2-1/2"	6'	29,000	2-1/2"	5'	31,000
40,000	3"	11-1/2'	54,000	3"	10'	57,000	3"	8'	62,000
60,000	4"	13-1/2'	80,000	4"	11-1/2'	86,000	3"	12'	93,000
80,000	6"	13'	107,000	4"	15-1/2'	114,000	4"	11'	128,000
100,000	6"	16'	133,000	6"	14'	143,000	4"	15-1/2'	154,000
125,000	6"	20'	165,000	6"	17-1/2'	180,000	6"	14'	193,000
150,000	8"	20-1/2'	220,000	8"	17-1/2'	215,000	6"	17'	230,000
175,000	8"	24'	235,000	8"	20-1/2'	250,000	6"	20'	270,000
200,000				8"	23'	285,000	8"	19'	310,000
225,000							8"	21'	345,000
250,000							8"	24-1/2'	385,000

NOTE : PIPE COIL LENGTH INCLUDES ELBOWS - 1 ELBOW = 1-1/2 FT OF PIPE

COIL-CAGE BURNERS

BULLETIN 3230
PAGE NO. 6

DIMENSIONS

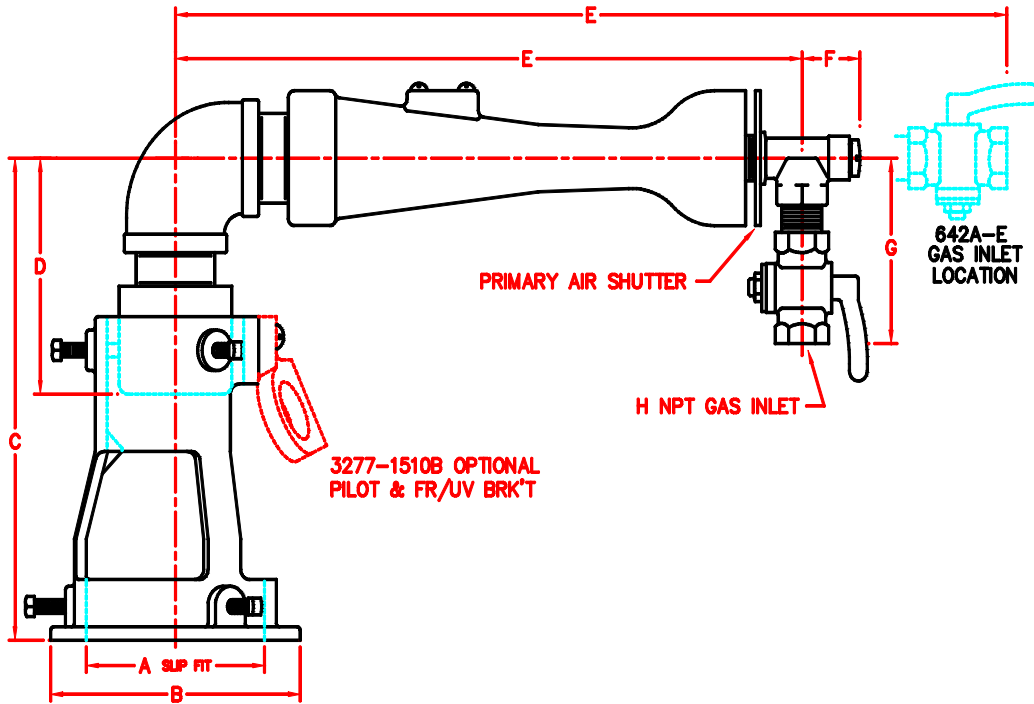

CATALOG NUMBER	A SLIP FIT	B	C + or - 1/4	D	E	F	G	H NPT
20A-E8	3-1/8	4-5/8	7-1/4	3-7/8	9-5/8	2	2-3/8	3/8
20A-E10	3-1/8	4-5/8	8	4-3/8	13-1/4	1-1/4	3-1/2	1/2
24A-E10	3-3/4	5-1/4	9	4-3/8	13-1/4	1-1/4	3-1/2	1/2
24A-E12	3-3/4	5-1/4	9-1/4	4-7/8	13-3/8	1-1/4	3-1/2	1/2
32A-E12	4-3/4	6-1/4	9-5/8	4-7/8	13-3/8	1-1/4	3-1/2	1/2
32A-E16	4-3/4	6-1/4	9-7/8	5-3/4	18-3/4	1-5/8	4-3/4	1
481A-E12	6-7/8	8-1/2	10-1/4	4-7/8	13-3/8	1-1/4	3-1/2	1/2
481A-E16	6-7/8	8-1/2	10-1/2	5-3/4	18-3/4	1-5/8	4-5/8	1
482A-E20	6-7/8	8-1/2	11-1/4	6-1/2	21-3/4	1-5/8	4-5/8	1
482A-E24	7-7/8	8-1/2	11-3/4	7-1/4	24-3/4	1-5/8	4-3/4	1
641A-E24	9	9-1/2	11-1/2	7-1/4	24-3/4	1-5/8	4-3/4	1
642A-E320	9	9-1/2	13-3/4	37-3/8	-	-	-	1-1/4

NOTE : ALL DIMENSIONS ARE IN INCHES

ORDERING INFORMATION

Where high pressure gas is available the Lojector may be replaced with Hijector. Write giving complete gas data and we will gladly specify necessary equipment.

For Coil-Cage Pilots see bulletin 3271.

For Coil-Cage only see bulletin 3231.