

PILOT ORIFICE COCKS

MODELS: 1441-1SCP, 1441-1SCT
 1441-2TSV, 1441-3TSV,
 1441-3TSV-FM,
 1441-4TSV-F

BULLETIN
 1441

Revision: 0

DIMENSIONS -- 1441-1SCP

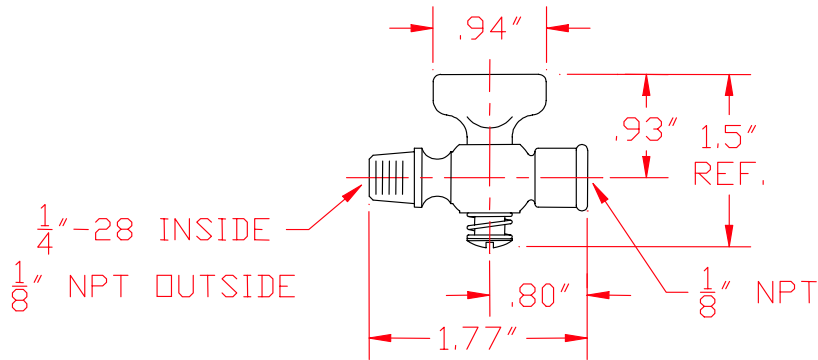

1 SCP Pilot Orifice Shut-off Cock
 1/4"-28 Tap for Orifice Plug
 0.5 psig Maximum Pressure
 Weight = 0.13 lbs.

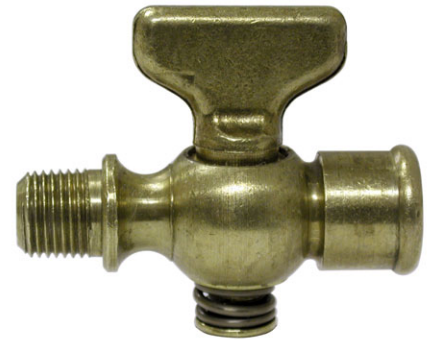

1441-1SCP

DIMENSIONS -- 1441-1SCT

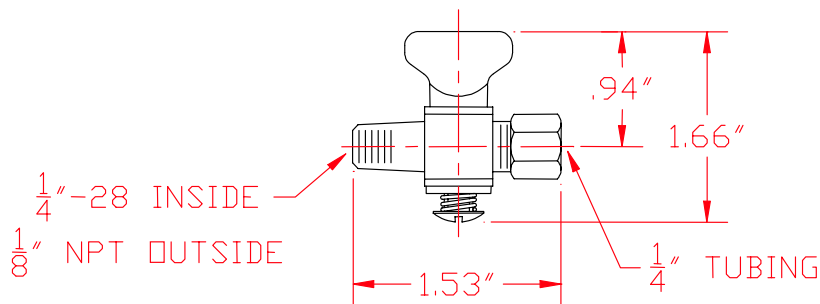

1 SCT Pilot Orifice Shut-off Cock
 1/4"-28 Tap for Orifice Plug
 0.5 psig Maximum Pressure
 Weight = 0.15 lbs.

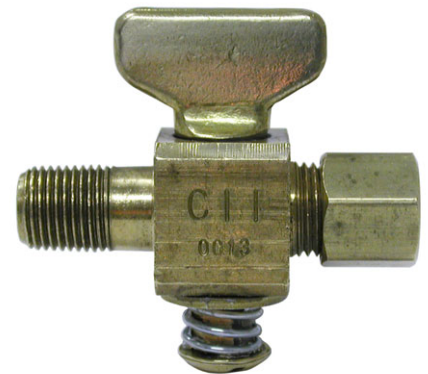

1441-1SCT

CAUTION: Operation of combustion equipment can be hazardous resulting in bodily injury or equipment damage. Each burner should be supervised by a combustion safeguard and only qualified personnel should install, make system adjustments and perform any required service.



pyronics inc.

COMBUSTION FOR INDUSTRY
 17700 MILES ROAD
 CLEVELAND, OH 44128
 www.pyronics.com

Tel: 216-662-8800
 Fax: 216-663-8954
 marketing@pyronics.com

NOTICE: PYRONICS practices a policy of continuous improvement in the design of its products. It reserves the right to change the specifications at any time without prior notice.

PILOT ORIFICE COCKS

BULLETIN
1441
PAGE NO. 2

DIMENSIONS -- 2TSV ADJUSTABLE THROTTLE COCK

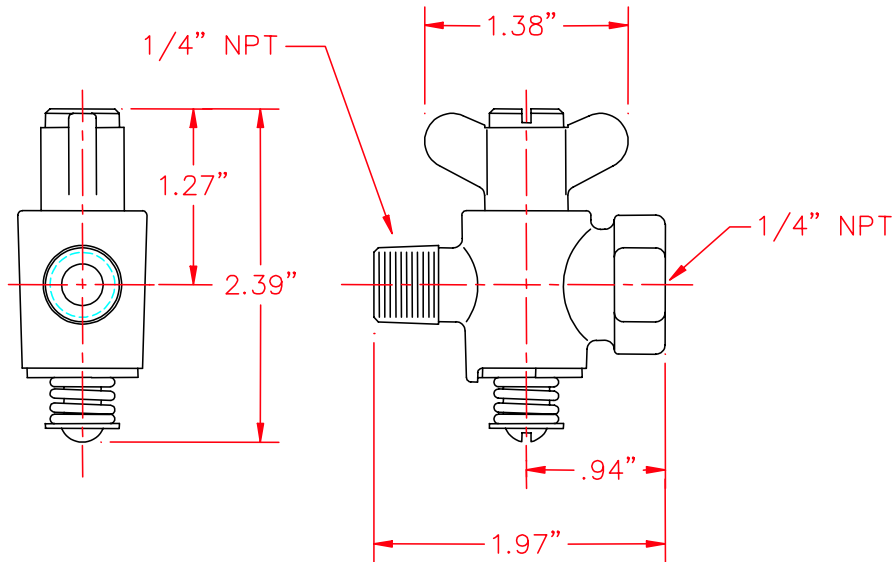

0.5 psig Maximum Pressure, CSA Certified
Weight = 0.33 lbs.

DIMENSIONS -- 3TSV ADJUSTABLE THROTTLE COCK

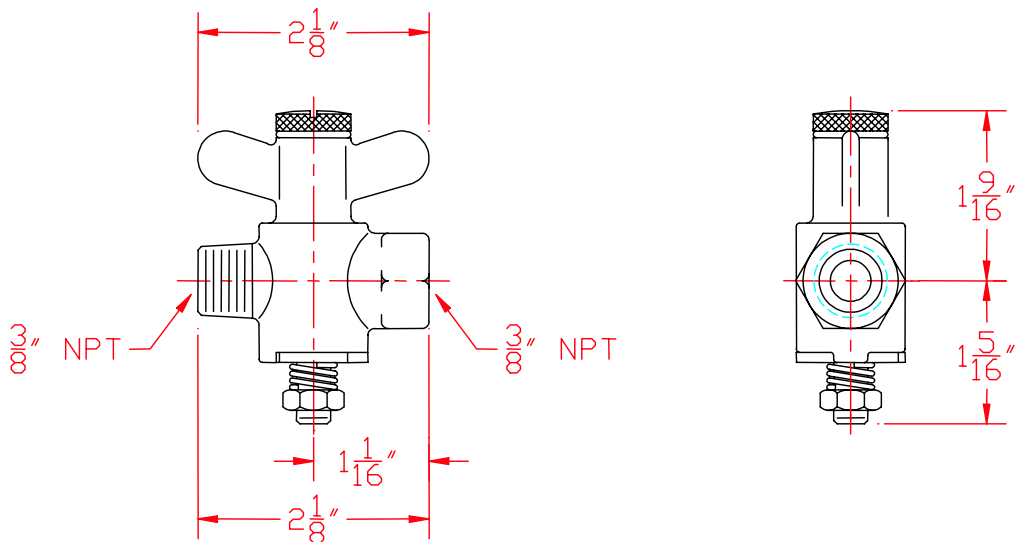

Model Number	Inlet Size	Outlet Size	Capacity Btu/hr.	FM	AGA	Max. Pressure psig	Weight Lbs.
1441-3TSV	3/8"	3/8"	175,000		X	0.5	0.53

Design Certified by the American Gas Association. Tested for operation at 32° - 250° F.

PILOT ORIFICE COCKS

BULLETIN
1441
PAGE NO.3

DIMENSIONS -- 3TSV-FM THROTTLING SHUTOFF COCK

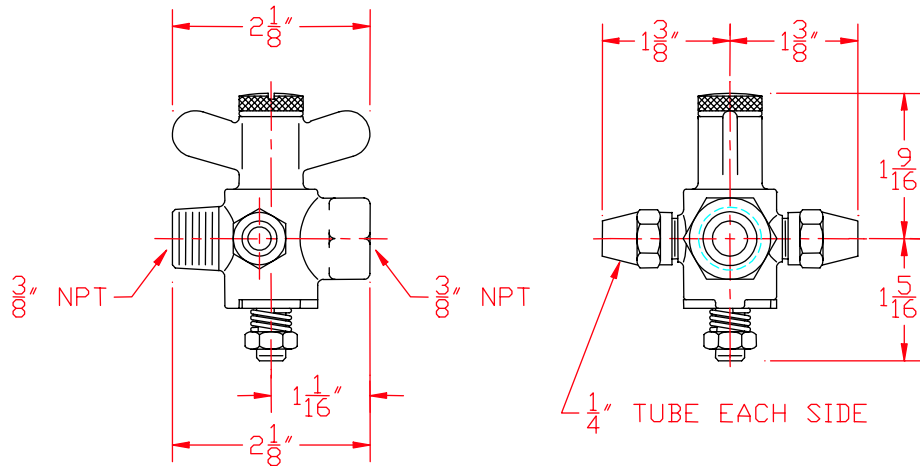

Model Number	Inlet Size	Outlet Size	Capacity Btu/hr.	FM	AGA	Max. Pressure psig	Weight Lbs.
1441-3TSV-FM	3/8"	3/8"	175,000	X		1.0	0.61



3TSV-FM THROTTLE COCK

Models 3TSV-FM and 4TSV-F feature a slotted throttle adjustment continuously adjustable from full open to full closed. Throttle setting is maintained independently of normal on-off operation. Model 3TSV-FM is a Factory Mutual Approved safety cock incorporating two 1/4 inch copper tubing checking system connections. This model functions as a supervising cock when linked by the two side outlets to a gas safety control system which insures all gas burner valves in a multi-burner system are closed.

1. Install valve with accepted good piping practices and in accordance with FM requirements and local codes.
2. Maximum pressure rating is 1.0 psig.

CAUTION: Operation of combustion equipment can be hazardous resulting in bodily injury or equipment damage. Each burner should be supervised by a combustion safeguard and only qualified personnel should install, make system adjustments and perform any required service.



pyronics inc.

COMBUSTION FOR INDUSTRY
17700 MILES ROAD
CLEVELAND, OH 44128
www.pyronics.com

Tel: 216-662-8800
Fax: 216-663-8954
marketing@pyronics.com

NOTICE: PYRONICS practices a policy of continuous improvement in the design of its products. It reserves the right to change the specifications at any time without prior notice.

PILOT ORIFICE COCKS

BULLETIN
1441
PAGE NO. 4

DIMENSIONS -- 4TSV-F THROTTLING SHUTOFF COCK

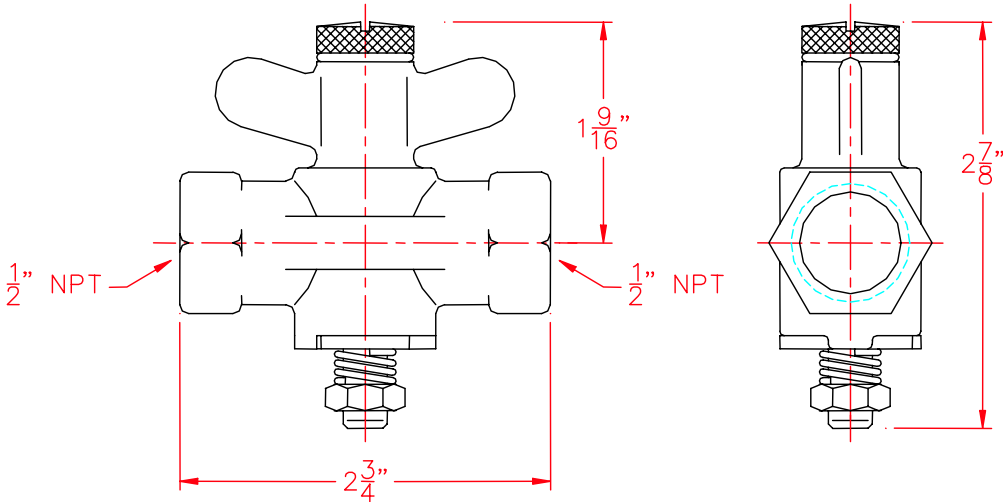

Model Number	Inlet Size	Outlet Size	Capacity Btu/hr.	FM	CSA	Max. Pressure psig	Weight Lbs.
1441-4TSV-F	1/2"	1/2"	175,000		X	0.5	0.75

ORDERING INFORMATION

1. Specify Model Number and Quantity
2. Shipping Instructions