

VALVES HYDRAMOTORS

MODEL: 1201 - AH2B
1201 - V710

Revision: 0

BULLETIN
1201

DESCRIPTION

Designed for main line gas control, the AH2D/V710 Hydramotor Gas Valve operates from a single contact ON-OFF type limit control to provide tight shut-off of dry natural, mixed, manufactured or LP gases. Not suitable for coke gas and sulphur bearing fuel gas service. Available in slow or fast opening models with spring return shut-off time of less than one second for boilers, furnaces, ovens and all types of gas-fired commercial or industrial burners.

Consists primarily of two components: the AH2D Actuator and the V710 Valve. Actuator is easily rotatable for best positioning of damper and electrical terminals. Position indicator furnished standard. Optional field reversible damper arm.

The valve is a globe type, 2-way normally closed, die-cast body and bonnet with a soft synthetic seat disc. It houses a return or valve seating spring and is designed to protect the valve stem from damage when the actuator is not attached. This feature permits in-line valve and actuator installation on jobs where construction continues after the installation of boilers or furnaces. There is no fixed connection between the actuator push rod and valve stem. Standardized mounting dimensions allow the actuator to be mounted on any size V710 Series valve.

The entire unit may be mounted in any position to afford optimum system design flexibility.

ACTUATOR SPECIFICATIONS

Type	Electro-hydraulic, oil-immersed duplex pump mechanism – Spring loaded piston. Travel limit switch operation – NEMA type 1 General Purpose Enclosure.
Stem Force	200 lb.
Seating Force	22 lb.
Stroke	1-1/4" Max.
Maximum Power Requirement	200VA
Timing	10 & 20 seconds nominal opening. 1 second closing. Valves will operate on 50 Hz. with a 20% increase in timing.
Position Indicator	Furnished standard on all models
Damper Arm	Optional – field adjustable for direct or reverse action. No special tools required. 2-7/8" length. 2-1/2" stroke. Maximum damper load 10 lbs.

VALVES SPECIFICATIONS

Type	Aluminum, 2-way globe type - Normally closed when in de-energized position.
Static Pressure Rating	25 psig
Ambient Temperature	- 40° F to +150° F maximum
Seat Material	Soft synthetic rubber
Guide Type	Quick-Opening



FEATURES

- Easily assembled from component stock with no special tools.
- All major valve and actuator components are field interchangeable.
- Tight shut-off -- 22 lb. seating force.
- Unique construction allows infinite actuator positioning for field wiring and installation ease.
- Optional field reversible damper arm.
- Operates to - 40° F with no accessory heaters.
- May be mounted to operate in any position.

APPROVALS



CAUTION: Operation of combustion equipment can be hazardous resulting in bodily injury or equipment damage. Each burner should be supervised by a combustion safeguard and only qualified personnel should install, make system adjustments and perform any required service.



pyronics inc.

COMBUSTION FOR INDUSTRY

17700 MILES ROAD
CLEVELAND, OH 44128
www.pyronics.com

Tel: 216-662-8800
Fax: 216-663-8954
marketing@pyronics.com

NOTICE: PYRONICS practices a policy of continuous improvement in the design of its products. It reserves the right to change the specifications at any time without prior notice.

VALVES HYDRAMOTORS

BULLETIN 1201
PAGE NO. 2

DIMENSIONS - ACTUATOR

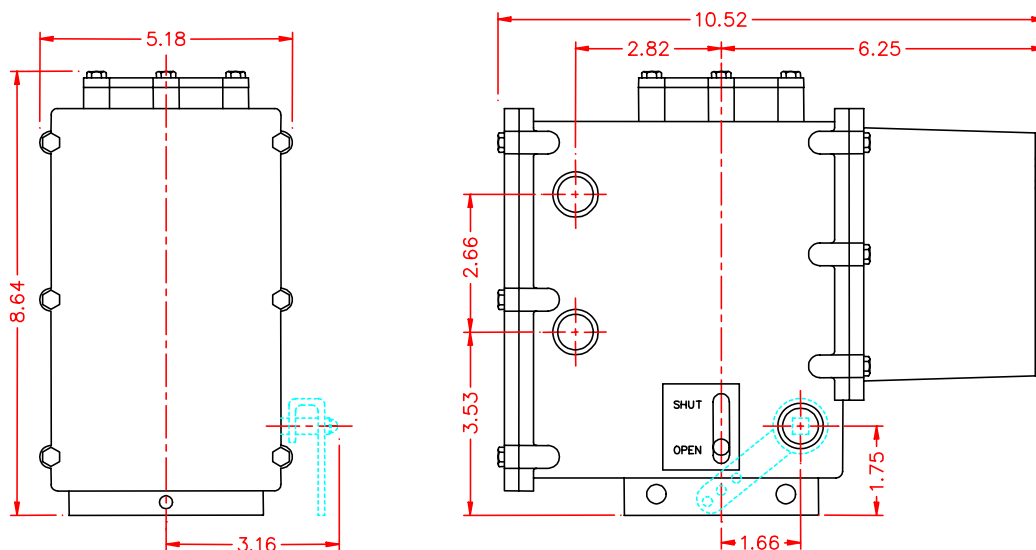

Type	Model No.	Timing Open/ Close (sec.)	Weight	
			Lbs.	Kgs.
Std. On-Off	AH2D102A	20/1	14.0	6.34
Std. On-Off	AH2D112A	10/1	14.0	6.34
Proof of Closure	AH2D102S	20/1	14.0	6.34
Proof of Closure	AH2D112S	10/1	14.0	6.34

Auxiliary Switches Adjustable to actuate at any position of stroke
 Rating 1 – SPDT switch, 15 amp @ 120V
 2 – SPDT switches, 7.5 amp @ 120V

To Order Switches 1 – SPDT switch, substitute 5 in place of 4
 2 – SPDT switches, substitute 5 + S107721B in place of 4

Operating Voltage	Amperes		
	Inrush	Opening	Holding
120 V - 60 Hz.	5.6	1.85	0.11

V710 SERIES - SPECIFICATIONS

Pipe Size (inches)	Minimum Cv Flow Factor	Minimum Gas Capacity* (Btu/Hr.)	Operating Pressure Differential (psi)		Fluid & Ambient Temperature (F)		Catalog Numbers			
			Min.	Max.	Min.	Max.	Quick-Opening Trim	Quick-Opening w/Valve Seal Overtravel Trim	Linear Trim	Linear w/Valve Seal Overtravel Trim
NORMALLY CLOSED (Closed when released)										
3/4	12	665,000	0	15	- 40	150	6V710EAS	6V710EASV22	6V710EASV15	6V710EASV25
1	17	960,000	0	15	- 40	150	8V710FAS	8V710FASV22	8V710FASV15	8V710FASV25
1-1/4	25	1,406,000	0	15	- 40	150	10V710GAS	10V710GASV22	10V710GASV15	10V710GASV25
1-1/2	30	1,717,000	0	15	- 40	150	12V710HAS	12V710HASV22	12V710HASV15	12V710HASV25
2	64	3,620,000	0	10	- 40	150	16V710JAS	16V710JASV22	16V710JASV15	16V710JASV25
2-1/2	75	4,250,000	0	10	- 40	150	20V710KAS	20V710KASV22	20V710KASV15	20V710KASV25
3	92	5,230,000	0	10	- 40	150	24V710LAS	24V710LASV22	24V710LASV15	24V710LASV25

* 1" W.C. Drop @ 2" W.C. Inlet Pressure, 1000 Btu/Cu. Ft. or more, 0.64 Specific Gravity Gas

VALVES HYDRAMOTORS

BULLETIN 1201
PAGE NO.3

DIMENSIONS - VALVE

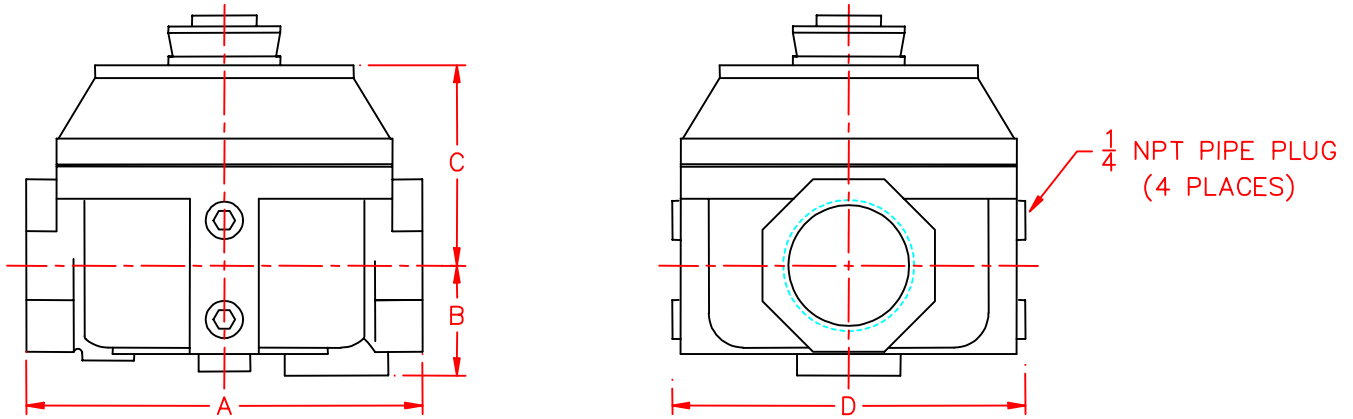

Model No. Valve Body with Quick-Opening Guide	Pipe Size NPT (in.)	Dimensions - Inches				Weight	
		A	B	C	D	Lbs.	Kgs.
6V710EAS	3/4	5.78	1.95	2.64	5.19	4.0	1.81
8V710FAS	1	5.78	1.95	2.64	5.19	4.0	1.81
10V710GAS	1-1/4	5.78	2.01	2.94	5.19	4.2	1.91
12V710HAS	1-1/2	5.78	2.01	2.94	5.19	4.2	1.91
16V710JAS	2	8.12	2.66	3.05	8.01	9.5	4.31
20V710KAS	2-1/2	9.00	2.96	3.87	8.01	13.0	5.90
24V710LAS	3	9.00	2.96	3.87	8.01	12.0	5.44

ORDERING INFORMATION

1. Specify Model Number and Quantity.
2. Shipping Instructions.

CAUTION: Operation of combustion equipment can be hazardous resulting in bodily injury or equipment damage. Each burner should be supervised by a combustion safeguard and only qualified personnel should install, make system adjustments and perform any required service.



pyronics inc.

COMBUSTION FOR INDUSTRY

17700 MILES ROAD
CLEVELAND, OH 44128
www.pyronics.com

Tel: 216-662-8800
Fax: 216-663-8954
marketing@pyronics.com

NOTICE: PYRONICS practices a policy of continuous improvement in the design of its products. It reserves the right to change the specifications at any time without prior notice.